

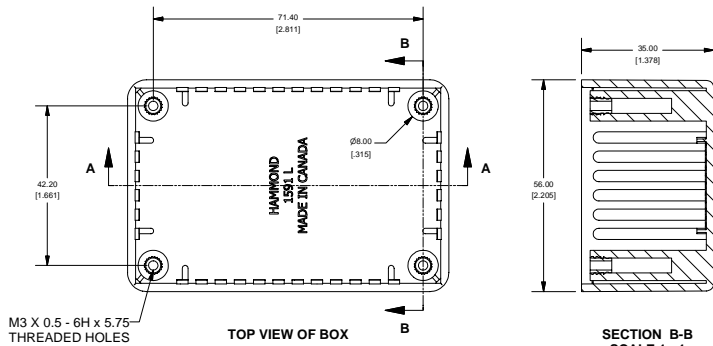

SIDE VIEW OF BOX



TOP VIEW OF BOX

M3 X 0.5 - 6H x 5.75
THREADED HOLES

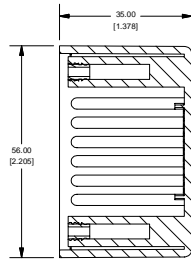

SECTION B-B
SCALE 1 : 1

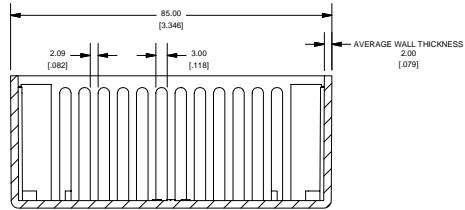

SECTION A-A
SCALE 1 : 1

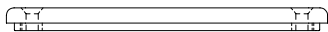

SIDE VIEW OF LID

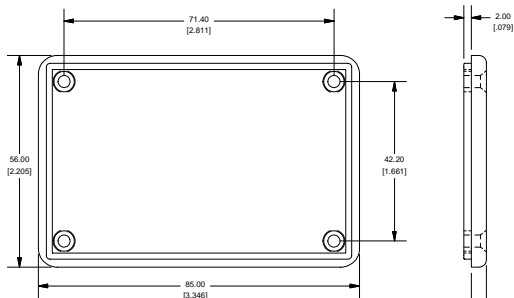

BOTTOM OF LID

SIDE VIEW OF LID

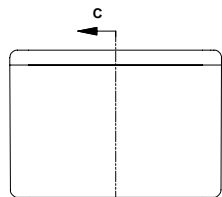

END VIEW OF ASSEMBLY

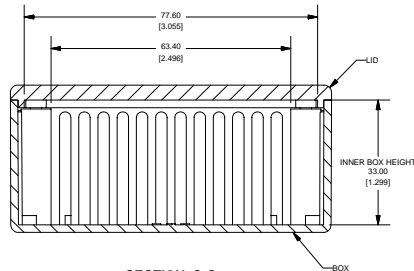

SECTION C-C
SCALE 1 : 1

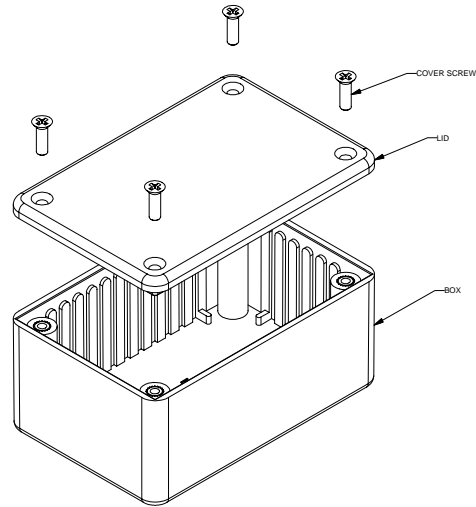

1591L

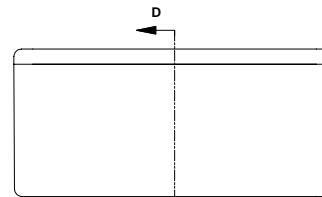

SIDE VIEW OF ASSEMBLY

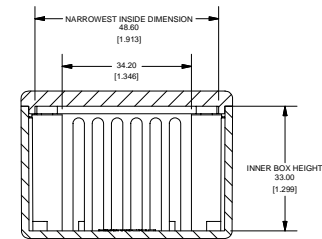

SECTION D-D
SCALE 1 : 1

PART NUMBERS

1591L Enclosures

Material	Colour	Part Number
ABS	Beige	1591LBG
	Black	1591LBK
	Blue	1591LBU
	Grey	1591LGY
GP ABS	Black Shielded	1591RLBK
Translucent Polycarbonate	Black	1591LSBK
	Ice Blue	1591LTBU
	IR Red	1591LTRD
	Crystal Clear	1591LTCL

Accessories

	Description	Part Number
Used with ABS and Translucent Polycarbonate Enclosures	PC Board Card Adapters	See Accessories Section
	Flange Kits	See Accessories Section
	Replacement Screws, nickel plated M3 - 0.5 x 10mm, Pack of 100.	1591MS100
	Belt/Pocket Clip, w/ nylon screws (insulated to avoid interference) and mounting template	1599CLIP - Black 1599CLIPGY - Grey
	Clear Lids - clear, flame retardant polycarbonate - Lid ONLY	1591LC
Used with GP ABS Enclosure	PC Board Card Adapters	See Accessories Section
	Flange Kits	See Accessories Section
	Belt/Pocket Clip, w/ nylon screws (insulated to avoid interference) and mounting template	1599CLIP - Black 1599CLIPGY - Grey
	Replacement Screws, self tapping, black oxide, #4 x 0.5, Pack of 100	1591TS100BK
	Clear Lids - clear, flame retardant polycarbonate - Lid ONLY	1591LC

Required Torque on Fasteners (no lubrication)

M3 - 0.5 x 10mm Screws	30-40 cN*m
#4 x 0.5 Screws	30-40 cN*m



www.hammondmfg.com